

SPARE PARTS LIST

Machine cutting torch MSZ 832-A/PMYE

Type of gases: acetylene, propane, methane, MAPP, ethylene

LISTE DES PIÈCES DE RECHANGE

Chalumeau coupeur machine MSZ 832-A/PMYE

Type de gaz: acétylène, propane, méthane, MAPP, éthylène

LISTA DE REQUESTOS

Soplete de corte de la máquina MSZ 832-A/PMYE

Tipo de gas: acetileno, propano, metano, MAPP, etileno

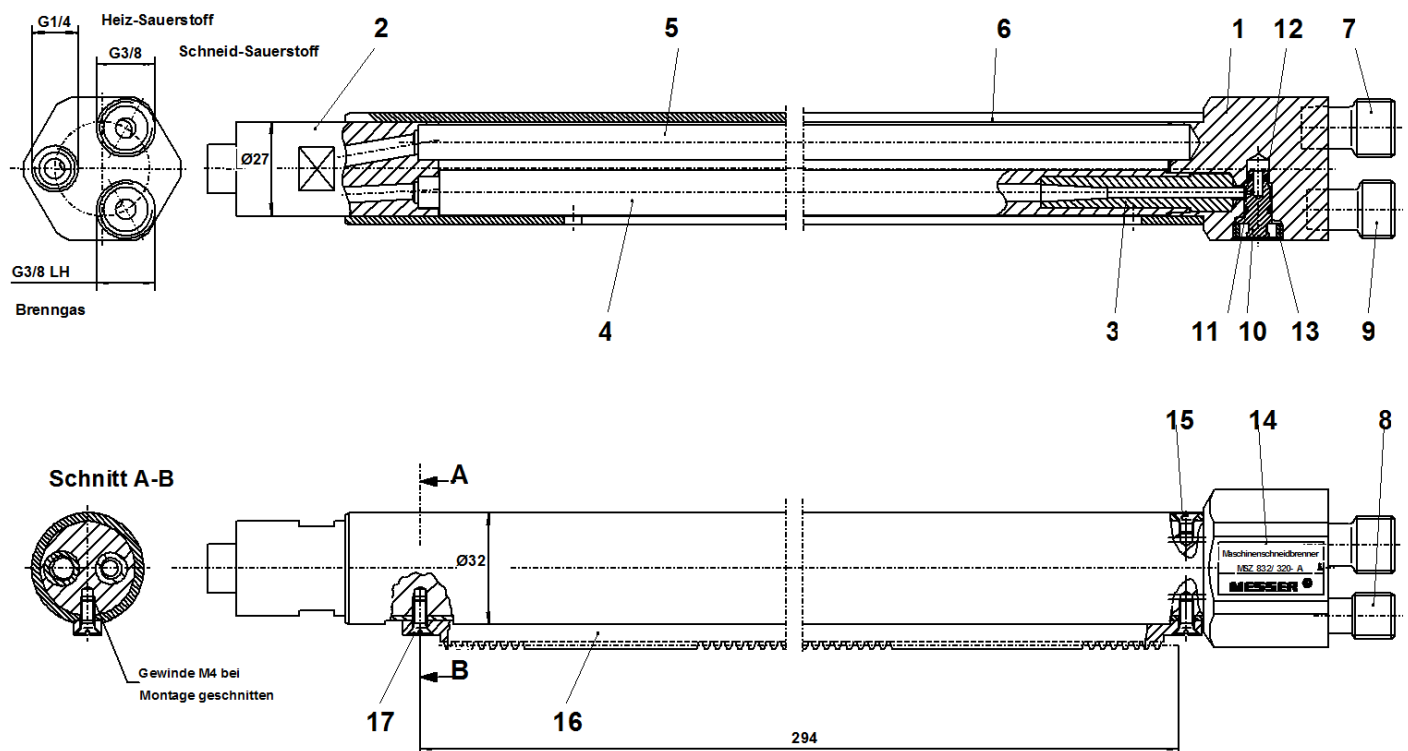

Pos. Item Pos.	Benennung Description Désignation Nombre	Sach. Nr. / Art. no. No. d'article / Art. No.	
1-17	Maschinenschneidbrenner MSZ Machine Cutting Torch MSZ Chalumeau coupeur machine MSZ Soplete de corte de la máquina MSZ	MSZ 832/320-A 716.11170	MSZ 832/320-PMYE 716.11171
1	Ventilkörper Valve body Corps de soupape Cuerpo de valvula	716.11119	→
2	Brennerkopf Torch head Tete porte-buses Cabeza del soplete	716.51204	→
3	Mischdüse Mixing nozzle Buse melangeuse Boquilla de mezcla	716.11120	→
4	Mischrohr Mixing tube Tube melangeur Tubo de mezcla	716.11212	→
5	Schneid-O2-Rohr Cutting oxygen tube Tube pour oxygene de coupe Tube para oxigeno de corte	716.11214	→
6	Führungsrohr Guide tube Canalisation de conduite Tubo de guía	716.51203	→
7	Gewindestutzen G3/8" Thread socket Manchon de fil Extremo roscado	677.01963	→
8	Gewindestutzen G1/4" Thread socket Manchon de fil Extremo roscado	677.51426	→

Ersatzteilliste

Spare Parts List

Maschinenschneidbrenner MSZ 832 – A/PMYE

für Ring-/Schlitzschneiddüsen

Brenngase: Acetylen, Propan, Methan, MAPP, Ethylen

Pos. Item Pos.	Benennung Description Désignation Nombre	Sach. Nr. / Art. no. No. d'article / Art. No.	
		MSZ 832/320-A	MSZ 832/320-PMYE
9	Gewindestutzen G3/8" LH Thread socket Manchon de fil Extremo roscado	677.01964	→
10	Druckdüse Pressure nozzle Injecteur Junta toroidal	716.11163	716.11172
11	O-Ring 5x1,5 O-ring Joint torique Junta toroidal	0.329.392	→
12	O-Ring 3x1,5 O-ring Joint torique Junta toroidal	770.20048	→
13	Gewindescheibe Thread disc Disque filete Disco roscada	540.11180	→
14	Typenschild Type plate Plaque signalétique Placa de tipo	716.11232	716.11233
15	Senkschraube M4x6 Countersunk screw Vis de fixation Tornillo avellabado	0.233.730	→
16	Zahnstange Rack Crémaillère Estante	716.51056	→
17	Senkschraube Countersunk screw Vis de fixation Tornillo avellabado	0.233.249	→

Werkzeuge und Zubehör für Maschinenschneidbrenner MSZ		MSZ 832/320-A	MSZ 832/320-PMYE	
Werkzeug für Druckdüse Tool for pressure nozzle Outil pour buse à pression Herramienta para la boquilla de presión		540.11250	→	
Düsensitzfräser Nozzle seat milling tool Fraise à siege de buse Fresa del asiento de la boquilla		0.939.005	→	
Schneiddüse A-RS Cutting nozzle Buse de découpe Boquilla de corte	2 – 8 mm	666.17101	—	
	3 – 10 mm	666.17102	—	
	10 – 25 mm	666.17103	—	
	25 – 40 mm	666.17104	—	
	40 – 60 mm	666.17105	—	
	60 – 100 mm	666.17106	—	
	100 – 200 mm	666.17107	—	
	200 – 300 mm	666.17108	—	
	Heizdüsen			
	2 – 100 mm	666.17115	—	
100 – 300 mm	666.17116	—		
Schneiddüse VADURA 1210-A Cutting nozzle Buse de découpe Boquilla de corte	2 – 5 mm	716.15760	—	
	3 – 5 mm	716.15761	—	
	6 – 10 mm	716.15762	—	
	10 – 25 mm	716.15763	—	
	25 – 50 mm	716.15764	—	
	50 – 80 mm	716.15765	—	
	80 – 100 mm	716.15766	—	
	100 – 150 mm	716.15769	—	
	150 – 230 mm	716.15948	—	
	230 – 300 mm	716.15949	—	
	Heizdüsen			
	3 – 150 mm	716.15770	—	
	150 – 300 mm	716.15951	—	
Schneiddüse VADURA +PLUS+ 1210-A Cutting nozzle Buse de découpe Boquilla de corte	2 – 5 mm	716.16171	—	
	3 – 5 mm	716.16172	—	
	6 – 10 mm	716.16173	—	
	10 – 25 mm	716.16174	—	
	25 – 50 mm	716.16175	—	
	50 – 80 mm	716.16176	—	
	80 – 100 mm	716.16177	—	
	100 – 150 mm	716.16178	—	
	150 – 230 mm	716.16179	—	
	230 – 300 mm	716.16180	—	
	Heizdüsen			
	3 – 150 mm	716.16181	—	
	150 – 300 mm	716.16182	—	

Zubehör für Maschinenschneidbrenner MSZ		MSZ 832/320-A	MSZ 832/320-PMYE
Schneiddüse VADURA 1215-A Cutting nozzle Buse de découpe Boquilla de corte	3 – 5 mm	716.15941	—
	6 – 10 mm	716.15942	—
	10 – 25 mm	716.15943	—
	25 – 40 mm	716.15944	—
	40 – 60 mm	716.15945	—
	60 – 100 mm	716.15946	—
	100 – 150 mm	716.15947	—
	150 – 230 mm	716.15948	—
	230 – 300 mm	716.15949	—
	Heizdüsen		
	3 – 150 mm	716.15950	—
	150 – 300 mm	716.15951	—
Schneiddüse VADURA +PLUS+ 1215-A Cutting nozzle Buse de découpe Boquilla de corte	3 – 5 mm	716.16161	—
	6 – 10 mm	716.16162	—
	10 – 25 mm	716.16163	—
	25 – 40 mm	716.16164	—
	40 – 60 mm	716.16165	—
	60 – 100 mm	716.16166	—
	100 – 150 mm	716.16167	—
	150 – 230 mm	716.16179	—
	230 – 300 mm	716.16180	—
	Heizdüsen		
	3 – 150 mm	716.16170	—
	150 – 300 mm	716.16182	—
Schneiddüse PL-RC Cutting nozzle Buse de découpe Boquilla de corte	2 – 8 mm	—	666.17225
	3 – 10 mm	—	666.17226
	10 – 25 mm	—	666.17227
	25 – 40 mm	—	666.17228
	40 – 60 mm	—	666.17229
	60 – 100 mm	—	666.17230
	100 – 200 mm	—	666.17231
	200 – 300 mm	—	666.17232
	Heizdüsen		
	Propan/Erdgas		
	2 – 100 mm	—	666.17235
	100 – 300 mm	—	666.17236
	Heizdüsen MAPP/ Ethylen		
	2 – 100 mm	—	716.15919
	100 – 300 mm	—	716.15920

Zubehör für Maschinenschneidbrenner MSZ		MSZ 832/320-A	MSZ 832/320-PMYE
Schneiddüse GRICUT 1230-PMYE Cutting nozzle Buse de découpe Boquilla de corte	3 – 10 mm	—	716.15901
	7 – 15 mm	—	716.15902
	15 – 25 mm	—	716.15903
	25 – 40 mm	—	716.15904
	40 – 60 mm	—	716.15905
	60 – 100 mm	—	716.15906
	Heizdüse 3 – 100 mm	—	716:15900
Schneiddüse GRICUT +PLUS+ 1230-PMYE Cutting nozzle Buse de découpe Boquilla de corte	3 – 10 mm	—	716.16147
	7 – 15 mm	—	716.16148
	15 – 25 mm	—	716.16149
	25 – 40 mm	—	716.16150
	40 – 60 mm	—	716.16151
	60 – 100 mm	—	716.16152
	Heizdüse 3 – 100 mm	—	716.16156
Schneiddüse GRICUT 1270-PY Cutting nozzle Buse de découpe Boquilla de corte	2 – 5 mm	—	716.15910
	3 – 5 mm	—	716.15921
	6 – 10 mm	—	716.15922
	10 – 25 mm	—	716.15923
	25 – 50 mm	—	716.15924
	50 – 80 mm	—	716.15925
	80 – 100 mm	—	716.15926
	Heizdüse Propan 2 – 100 mm	—	716.15930
	Heizdüse MAPP 2 – 100 mm	—	716.15932
	Schneiddüse GRICUT +PLUS+ 1270-PY Cutting nozzle Buse de découpe Boquilla de corte	3 – 5 mm	—
6 – 10 mm		—	716.16185
10 – 25 mm		—	716.16186
25 – 50 mm		—	716.16187
50 – 80 mm		—	716.16188
80 – 100 mm		—	716.16189
Heizdüse Propan 2 – 100 mm		—	716.16190
Heizdüse MAPP 2 – 100 mm		—	716.16191

Zubehör für Maschinenschneidbrenner MSZ		MSZ 832/320-A	MSZ 832/320-PMYE
Schneiddüse GRICUT 1280-PMYE Cutting nozzle Buse de découpe Boquilla de corte	100 – 200 mm	—	716.15927
	200 – 250 mm	—	716.15928
	250 – 300 mm	—	716.15929
	Heizdüse 100 – 300 mm	—	
	Sonderdüsen f. Verbundstein- formen 60 – 100 mm	—	716.15931
	100 – 150 mm	—	716.15938
		—	716.15933
Schneiddüse GRICUT +PLUS+ 1280-PMYE Cutting nozzle Buse de découpe Boquilla de corte	100 – 200 mm	—	716.16192
	200 – 250 mm	—	716.16193
	250 – 300 mm	—	716.16194
	Heizdüse 100 – 300 mm	—	716.16195

Bitte Reparaturanleitung beachten
 Please follow the repair instructions
 Veuillez respecter les instructions de réparation
 Rogamos prestar atención a las instrucciones de
 reparación

Änderungen vorbehalten
 Subject to alterations
 Droit de modification réserve
 Salvo modification

MESSER Cutting Systems GmbH
 Otto-Hahn-Str. 2-4
 D-64823 Groß-Umstadt
 Tel.: +49 (0) 6078 787-0
 Fax: +49 (0) 6078 787-150
 E-Mail: info@messer-cutting.com

© Messer Cutting Systems
 ® = registriertes Warenzeichen
 Quality management system